

Stepper Motor Power Stage with Supply Unit for 230V_{AC}

SP MINI Power Stages

The compact stepper motor power stages including supply unit are directly connected to the mains voltage 230 V_{AC} (option: 115 V_{AC}).

SP MINI are available with 5, 7 or 9 A_{PEAK} maximum phase current. The step resolution can be set by rotary switches from full step to 1/5 step.

Maximum use of the motor torque and a smooth stepper motor drive result from the rotating field synchronized current regulation based on the patented SYNCHROCHOP principle.

Optimum noise suppression between control and power circuit is obtained by optocouplers for electrical insulation of the push-pull inputs from the supply voltage.

Example of Connection

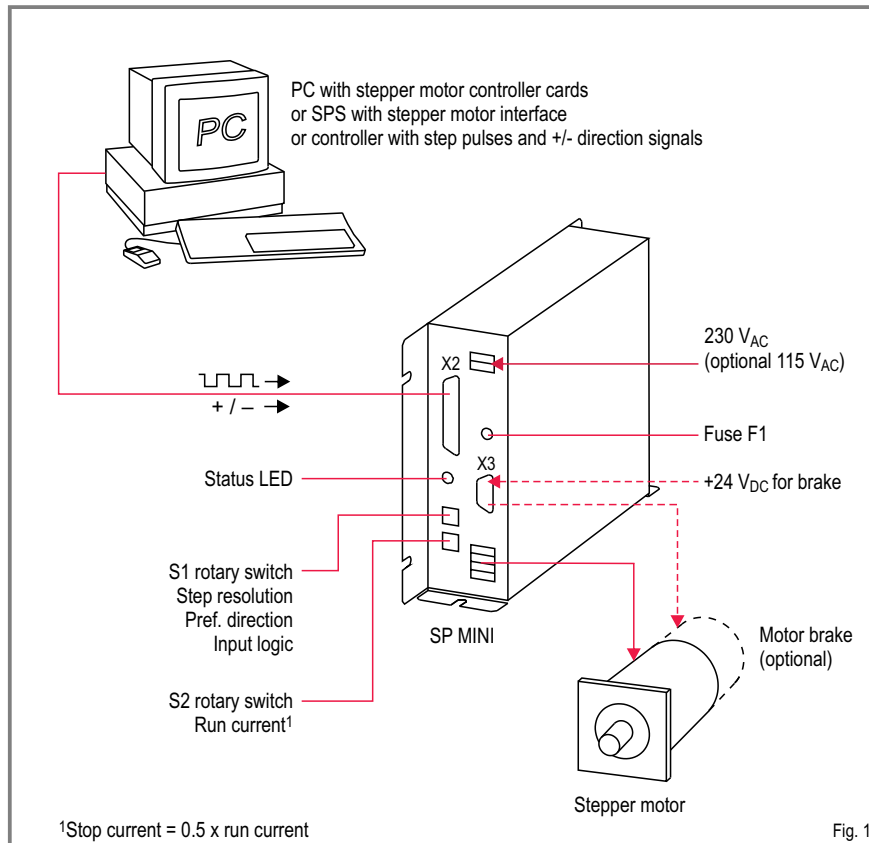

Application Ranges

The phytron SP MINI stepper motor power stages are used for positioning by PC and SPS controllers, e. g. in apparatus engineering or in application technology.

Control signals for SP MINI can be supplied by controllers with step pulses ±direction signals or PC with stepper motor interface.

Mounting brackets allow to mount the flat SP MINI housing alternatively vertical or horizontal in a switch cabinet depending on the allocated space.

The CE-conform device design meets the requirements of the EU directives when mounted EMC compliant.



Technical Information

- Ministep stepper motor power stage
- Supply unit for direct connection to the mains voltage 230 V_{AC}
Option: 115 V_{AC}
- Control of two-phase stepper motors
- 3 versions with the following phase currents:
SP MINI 92-70 max. 9 A_{PEAK}
SP MINI 72-70 max. 7 A_{PEAK}
SP MINI 52-70 max. 5 A_{PEAK}
- Motor voltage: 70 V
- Step resolution: Full step to 1/5 step
- Rotary switches for setting the run current, step resolution, pref. motor direction and logic of the input signals
- Electrical insulation of inputs and error output by optocoupler
- Electronic monitoring of overheating, short circuit and undervoltage
- Optional connection of stepper motor with permanent magnet motor brake
- Compact design for wall mounting
- Variable mounting position
- EMC compliant design

Dimensions

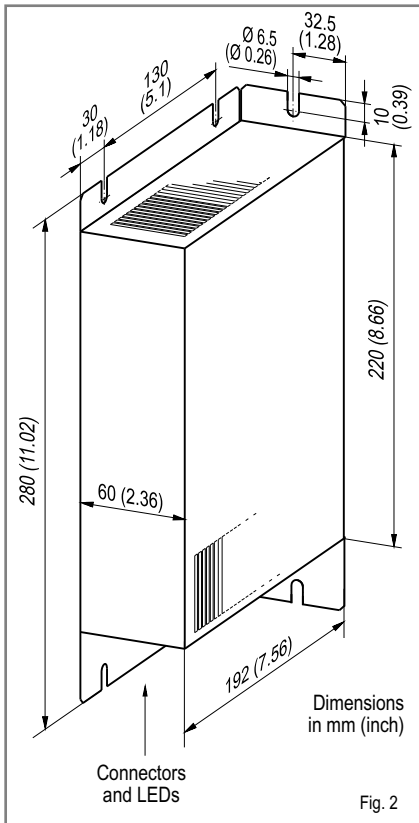

Inputs

The push-pull inputs – Control pulses, Motor direction, Deactivation, Reset, Boost and Brake – are electrically insulated from the power stage supply voltage by optocouplers. That way, an optimum noise suppression is achieved between control and power circuit.

High immunity is obtained when driving the SP MINI with RS422-push-pull signals (fig. 3), because the lines are permanently supplied.

Alternatively, an open collector controlling is also possible - see in manual SP MINI.

The standard logic voltage is +5 V, which can be changed to +24 V by additional series resistors.

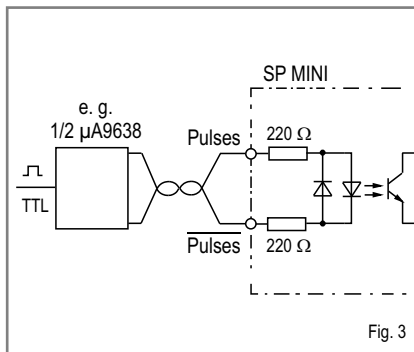

ERROR Output

Optocoupler open collector Darlington output

Nominal current = 20 mA, $U_{max} = 30 V$, U_{CEsat} at 20 mA < 1 V

ERROR is a common Error output for all error messages of SP MINI. This output is opened if certain limit values are exceeded and to avoid damaging the motor. The multi-color LED shines red. To reset the ERROR signal, the RESET input must be activated or the mains switched off temporary.

Limit values for an error message:

- Motor current > 14 A
- Motor supply voltage < 35 V
- Heat sink temperature > 85 °C

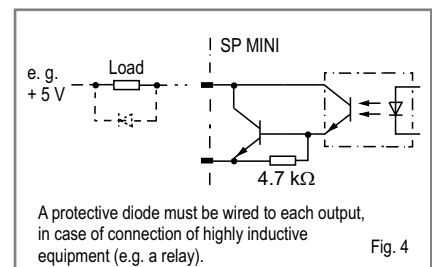

Motor brake

SP MINI supports the operation of stepper motors with a 24 V_{DC} / 0.75 A max. permanent magnet motor brake.

The brake is controlled via the BRAKE input (X2 connector): if this input is activated, the brake is supplied with current and the braking effect suppressed.

If an error signal occurs (X2 connector) or if the DEACTIVATION input is activated (X2 connector), the brake supply is interrupted, i.e. the brake activated.

The brake is connected to X3 connector. The brake supply voltage must be externally supplied to X3 connector.

Ordering Code

| | | SP MINI 92-70 115 V | |
|--------------------|---|---------------------|--|
| Type | SP MINI = Ministep power stage in flat pack | | |
| Peak current | 9 = 9 A | | |
| | 7 = 7 A | | |
| | 5 = 5 A | | |
| Current regulation | 2 = Power stage with SYNCHROCHOP | | |
| Motor voltage | 70 = Motor voltage 70 V | | |
| Option | 115 = Mains voltage 115 V | | |
| | (no indication: Mains voltage 230 V) | | |